

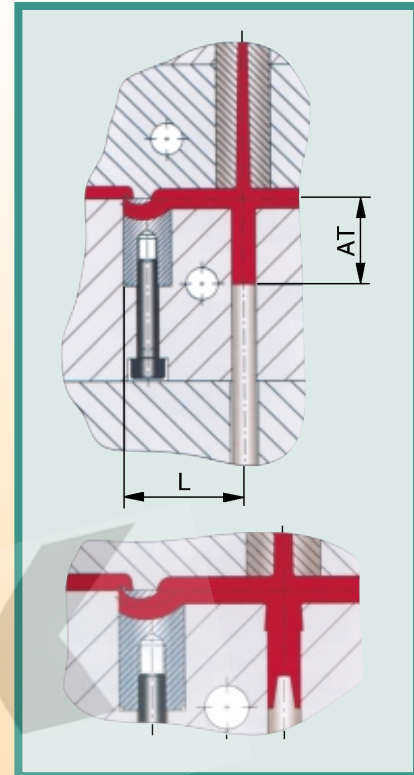

Cashew Gate Installation Data

Plastic Group	GTM	GTR/ GTE	GTK
HD-PE, LD-PE, PET, PP, PA, PC, PVC. (L)	>15	>20	>25
Runner Design	round	round	round
Ejector Depth (AT)	>11	>16	>20
ABS, M ABS, ASA, PS, PC/ABS, POM, PBT. (L)	>20	>25	>30
Runner Design	round	round	round
Ejector Depth (AT)	>14	>20	>24
Elastomers TPE, TPU, TPP, TPA. (L)	>15	>15	>20
Runner Design	arbitrary	arbitrary	arbitrary
Ejector Depth (AT)	>11	>11	>16
Brittle Plastics (L)	>25	>30	>40
Runner Design	half round	half round	half round
Ejector Depth (AT)	>18	>24	>32



Plastic Group	GRF	GXK
HD-PE, LD-PE, PET, PP, PA, PC, PVC. (L)	>30	>35
Runner Design	round	round
Ejector Depth (AT)	>30	>35
ABS, M ABS, ASA, PS, PC/ABS, POM, PBT. (L)	>30	>40
Runner Design	round	round
Ejector Depth (AT)	>30	>40
Elastomers TPE, TPU, TPP, TPA. (L)	>20	>30
Runner Design	arbitrary	arbitrary
Ejector Depth (AT)	>20	>30
Brittle Plastics (L)	on request	on request
Runner Design	half round	half round
Ejector Depth (AT)	on request	on request

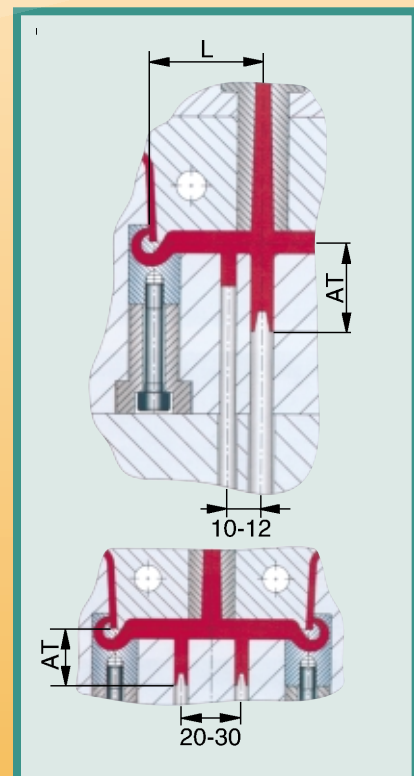

Recommended distances 'L' from the injection point to the sprue ejector for various material groups. The distance 'AT' is the correlated ejector depth.

CAD files available at:
www.exaflow.com

