

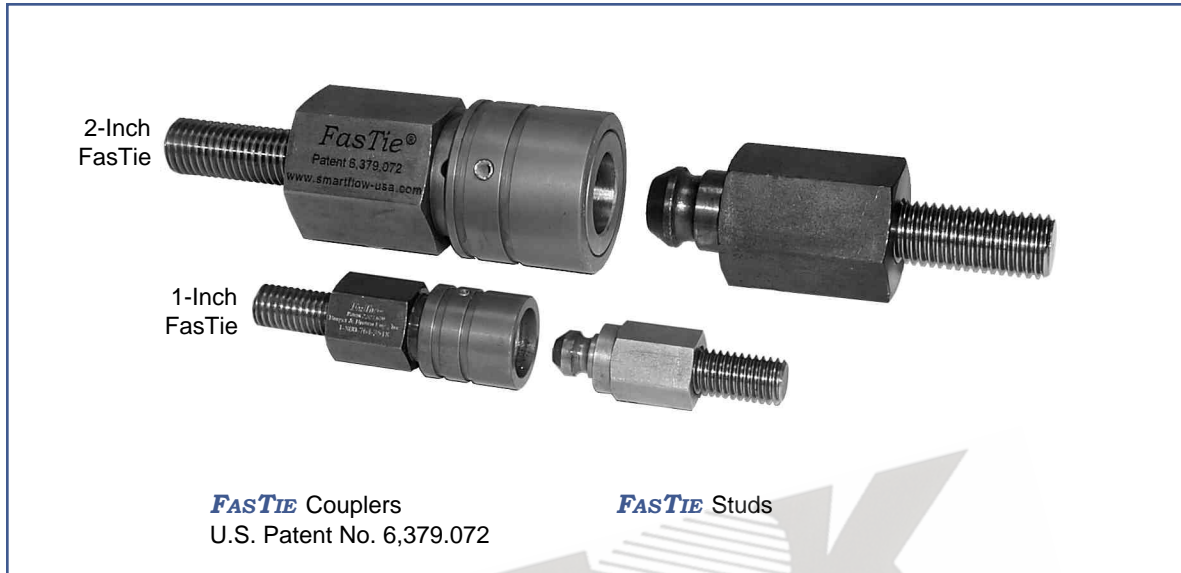

FASTIE[®] - Quick Ejector Tie-In System



Description & Use

In an injection molding press, the **FASTIE** system quickly “ties-in” the mold ejector plate to the press ejection system, dramatically reducing mold change time. The greatest time savings are realized in presses where space is limited and the ejector system is difficult to tie in using solid knock-out bars.

The **FASTIE** coupler is permanently mounted to the press ejector plate. The quick-connect locking mechanism in the coupler snaps mechanically onto the mold-mounted stud during mold installation.

To release the ejectors, apply shop air to the coupler. The coupler opens to release the stud, disconnecting the press and tooling ejector plates. The coupler remains in the open position, ready for a new mold to be set.

For multiple ejector locations, an air manifold is recommended to release all couplers simultaneously. See inside catalog pages for installation examples.

Two **FASTIE** sizes are available: 1-inch model for presses 500 tons and under and 2-inch model for presses larger than 500 tons.

Accessories

The **FASTIE** system features additional parts to aid installation and use. These accessories can be used in combination to accommodate your specific press and mold applications. Different thread sizes are available to suit most presses and molds.

- **K-LINK**[™] Ejector Cushions*
- **SPEEDBAR**[®] Adjustable Length Ejector Bars*
- Fixed Length Blank Ejector Bars
- Center Knockout Adapters
- Center Knockout Bars
- Air Manifolds

* 1-inch only

**bunger &
brown**
engineering, inc.

Tel. 800-764-3518
www.smartflow-usa.com

*Design and specifications are
subject to change without notice.*



FASTIE® Installation Examples

Typical Application for 2 or 4 Ejector Positions

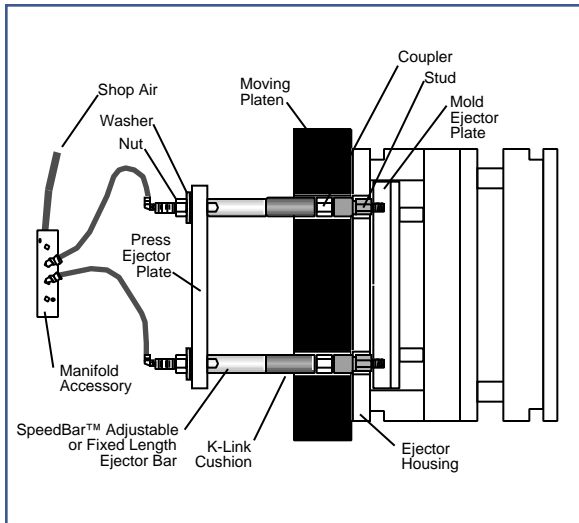

This setup is designed for captive molders, or shops with tools using a standard thickness ejector housing.

Couplers are located at the end of the ejector bars. Studs are mounted to each mold in storage. Ejector connection is made without changing ejector bars.

Ejector housing shown is 1.062" thick. The Air Manifold supplies compressed air to the end of each ejector bar for simultaneous coupler release. Fixed length bars are finished on site, cut to length and tapped with 1/2-13 female thread.

Parts List

Qty	Part
2 or 4	FasTie Stud
2 or 4	FasTie Coupler
2 or 4	K-Link™ Ejector Cushion (optional)
2 or 4	Fixed Length Ejector Bars or SpeedBar® Adjustable Length Bars
1	Air Manifold with tubing

To determine the correct ejector bar length for 1-inch FasTie, use the following formula:

Existing Ejector Tie-Bar Length

- 1.062" (ejector stud when connected)
 - 2" (FasTie Coupler in closed position)
 - 3.75" (K-Link if present)
- = Basic SpeedBar or Fixed Bar Length

Alternate Application for 2 or 4 Ejector Positions

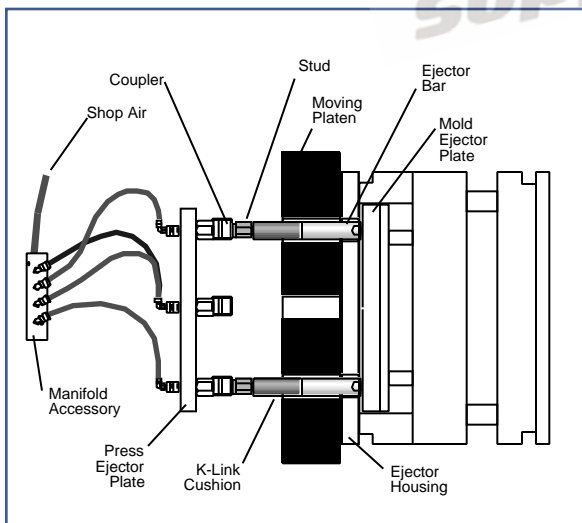

This setup is designed for custom molders who use a variety of injection molds with different ejector patterns and ejector housing thicknesses.

Couplers are installed next to the Press Ejector Plate. Male studs are placed at the end of the ejector bars for easy removal. Molds are changed quickly without accessing the back of the Press Ejector Plate. Ejector bars can be changed on the mold side by threading into the ejector plate.

Parts List

Qty	Part
2 or 4	FasTie Stud
2 or 4	FasTie Coupler
2 or 4	K-Link Ejector Cushion (optional)
2 or 4	Fixed Length Ejector Bars or SpeedBar Adjustable Length Bars
1	Air Manifold with tubing

For example, a press with 4 ejector positions may be running molds using only the horizontal positions, but the next mold may need the 2 vertical ejector positions. Ejector housing shown is 1.062" thick.

Air Manifold supplies air to the end of each ejector bar for simultaneous coupler release.



FASTIE® Installation Examples

Alternate Application for 2 or 4 Ejector Positions

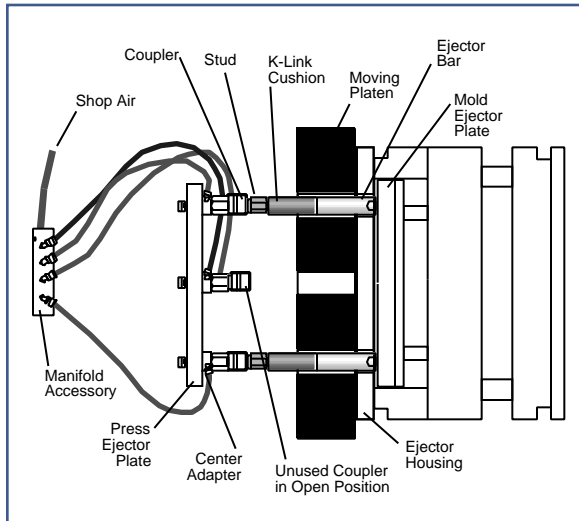

This setup is used where there is limited access to the back of the Press Ejector Plate. Custom molders using smaller presses will benefit from this application.

Couplers are installed next to the Press Ejector Plate. Male studs are placed at the end of the ejector bars for easy removal. Molds are changed quickly without accessing the back of the Press Ejector Plate. Ejector bars can be changed on the mold side by threading into the mold ejector plate.

For example, a press with 4 ejector positions may be running molds using only the horizontal positions, but the next mold may need the 2 vertical ejector positions.

Ejector housing shown is 1.062" thick.

Air Manifold supplies air to the mold side of the Press Ejector Plate with the use of adapters.

Parts List

Qty	Part
2 or 4	FasTie Stud
2 or 4	FasTie Coupler
2 or 4	Center Adapters
2 or 4	K-Link™ Ejector Cushion (optional)
2 or 4	Fixed Length Ejector Bars or SpeedBar® Adjustable Length Bars
1	Air Manifold with tubing

Center Ejector Position

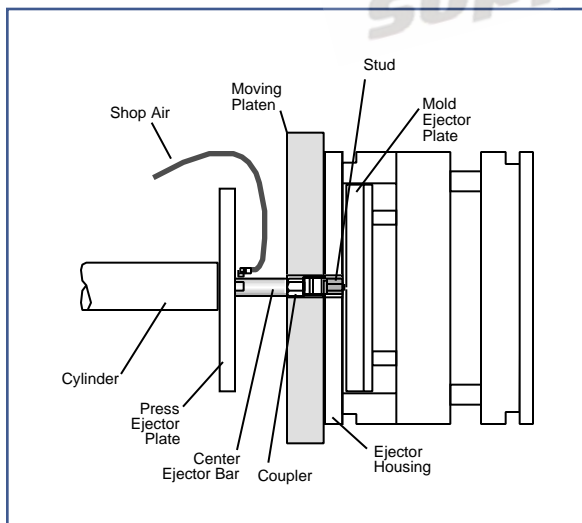

For small presses with a center ejector, replace the cylinder bolt with a Center Ejector Bar and FasTie coupler.

Center Ejector Bar is installed into the Press Ejector Plate, with the Coupler attached to the end. The Stud is installed in the Mold Ejector Plate. Molds are changed quickly without accessing the back of the Press Ejector Plate.

Ejector housing shown is 1.062" thick.

Shop air is supplied to the side of the center adapter. No manifold is needed. Fully-threaded Center Ejector Bar may be shortened to proper length on-site. In many small machines, there may not be room for a K-Link cushion or an ejector bar.

Parts List

Qty	Part
1	FasTie Stud
1	FasTie Coupler FTF-63
1	Center Ejector Bar



FASTIE[®] Specifications and Accessories

Features & Benefits

- **FASTIE[®]** installs easily into existing tapped holes, no additional machining is required.
- **FASTIE[®]** reduces mold setting time by quickly uncoupling, plus there are no loose parts to stow.
- **FASTIE[®]** remains coupled during mold cycling for increased "tie-in" reliability and reduced wear.
- **K-LINK[™]** cushion helps protect valuable presses and ejector system parts from damage due to improper setup.*
- **SPEEDBAR[™]** adjusts quickly without tools to the exact length required ($\pm 1/2"$ (12.7mm) from nominal in .006" (.15mm) increments)*.
- **SPEEDBAR[™]** relieves molders from the time and trouble of machining ejector bars to fit different molds.*

* 1-inch only

Specifications

Allowable press tonnage:	1-inch	500 tons
	2-inch.....	500 tons
Maximum operating temp.....	300°F (149°C)	
Air pressure range.....	80 - 100 psi	
Stud material.....	Hardened Steel	
Ejector bar and coupler material.....	High Strength Steel	
Air manifold material.....	Aluminum	
Air tubing material.....	1/8"OD Nylon	

Press requirements:

	Coupler Size	
	1-inch	2-inch
Platen thru hole min.	ø1.063"	ø2.063"
	ø27mm	ø52.4mm
Ejector plate thru hole min.	ø0.512"	ø0.765"
	ø14mm	ø19.4mm
Ejector force per coupler max.	2.5 tons	7.5 tons

K-Link[™]

K-LINK ejector cushion is a shock-absorber for the ejector system of an injection molding press. The K-Link helps protect molds, ejector bars, and the injection molding press from fatigue due to harsh forces present during part ejection. The K-Link also protects against a mis-adjusted ejector home position up to 1mm or .040".

Typical ejector systems apply 5 to 12 tons of force upon expensive mold and machine components. Constant pounding during ejection (especially rapid, multiple ejector strokes) fatigues ejector components; wear or damage is not immediately evident. Over time, ejector system linkage weakens and may break without warning. Resulting machine and mold repair is costly in terms of parts, labor and machine down-time. The K-Link ejector cushion and a periodic maintenance program helps protect you from these preventable losses.

Use the K-Link to prevent damage to the FasTie couplers. The K-Link can also stand alone as a shock-absorber used with your existing ejector bars.

For use with 1-inch FasTie only.

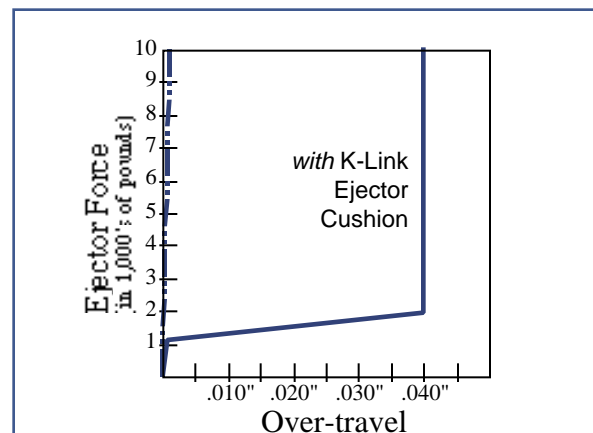

Ejector Force vs. Over-travel at work upon injection mold and press components with and without K-Link cushion installed



FAS TIE[®] Accessories



Fixed Length Ejector Bar

Accessories (continued)

Fixed Length Ejector Bar is a solid bar that provides an air passage from the back of the press ejector plate to the FasTie Coupler. Several lengths are stocked with one blank end for on-site finishing.



SPEEDBAR

U.S. Patent No. 6,315,544

SPEEDBAR is an adjustable length ejector bar that quickly compensates for variations in different molds. Used with the FasTie system, mold ejector plate tie-in and adjustment times are significantly reduced. The adjustment sleeve is rotated without tools to shorten or lengthen the bar length up to 1/2" in increments of .006". Once the desired length is set, the spring-loaded sleeve securely locks in your adjustment.

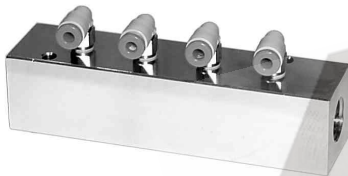

Air Manifold

Air Manifolds, Center Adapters, and Center Ejector Bars aid in installation of the FasTie System. See pages 2 and 3 for Installation Examples. Custom sizes are available.



Center Adapter



Center Ejector Bar



FAS TIE® Part Numbers

1-Inch Part Numbers

Couplers	
Model Number	Thread Size
FTF-50	1/2-13(M)
FTF-63	5/8-11(M)

Studs	
Model Number	Thread Size
FTM-38	3/8-16(M)
FTM-50	1/2-13(M)
FTM-63	5/8-11(M)
FTCS-4	1/2-13(F)
FTM-16-2M	M16x2

Ejector Bars				
Measure ejector length very closely (within ± 0.002 ") to insure proper ejector bar function. Subtract 2" length for FasTie coupler, and 3.75" length for the K-Link cushion when used.	Fixed Length Blank		SpeedBar™ Adjustable $\pm 1/2$ "	
	Model Number	Length	Model Number	Length
	FTBB-50-8	8"	SBAB-50-6	6"
	FTBB-50-10	10"	SBAB-50-7	7"
	FTBB-50-12	12"	SBAB-50-8	8"
	FTBB-50-14	14"	SBAB-50-9	9"
			SBAB-50-10	10"
			SBAB-50-11	11"
			SBAB-50-12	12"
			SBAB-50-13	13"
			SBAB-50-14	14"

Center Adapters	
Model Number	Thread Size
FTCA-63M-0.5	5/8-11(M)
FTCA-16M-0.5	M16 x 2(M)

Center Bars	
Model Number	Thread Size
FTCA-63M-63F	5/8-11(M)
FTCA-16M-63F	M16(M)

K-Link and Air Manifold	
FTKL-50	<i>K-LINK</i> Cushion
FTAM-100	Air Manifold Assembly

2-Inch Part Numbers

Couplers	
Model Number	Thread Size
FTF2-63	5/8-11(M)
FTF2-16	M16x2(M)

Studs	
Model Number	Thread Size
FTM2-63	5/8-11(M)
FTM2-75	3/4-10(M)
FTM2-16	M16x2(M)

Center Adapters	
Model Number	Thread Size
FTCA2-75M-0.5	3/4-10(M)
FTCA2-16M-0.5	M16x2(M)

**Ejector Bars for 2-Inch FasTie are special orders.
Contact your representative for information**



FASTIE® Dimensions, 1-inch Components

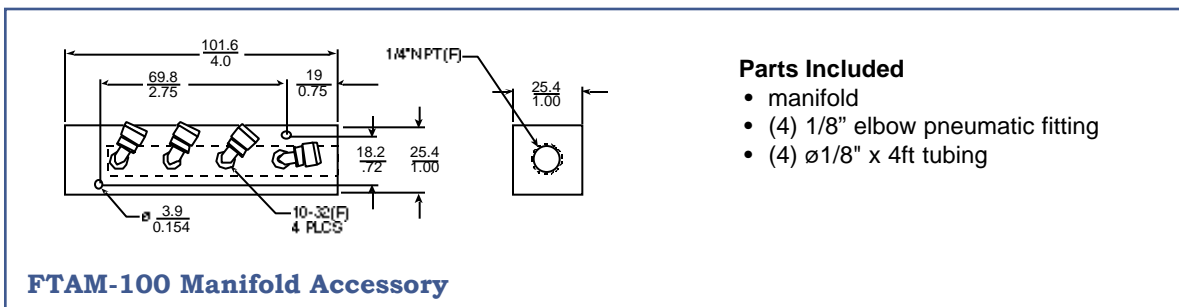
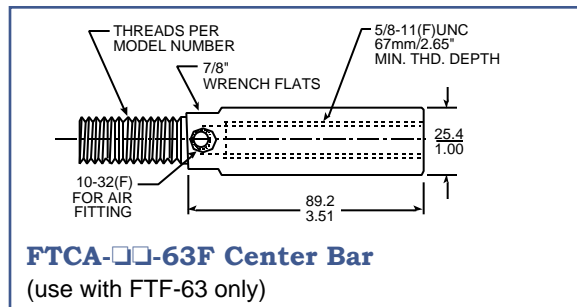
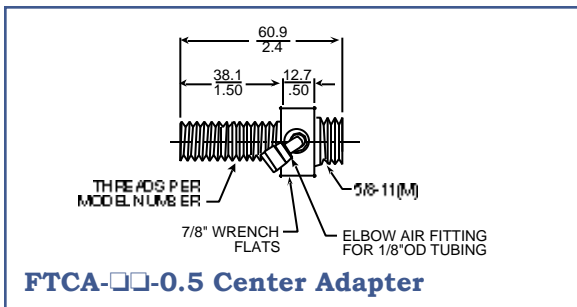
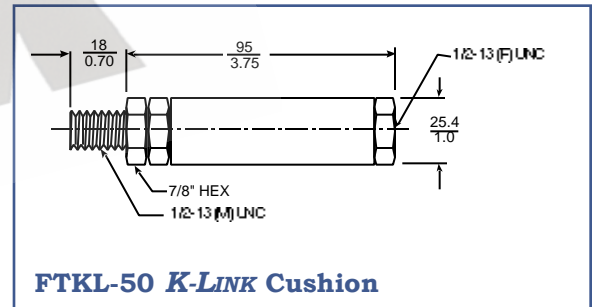
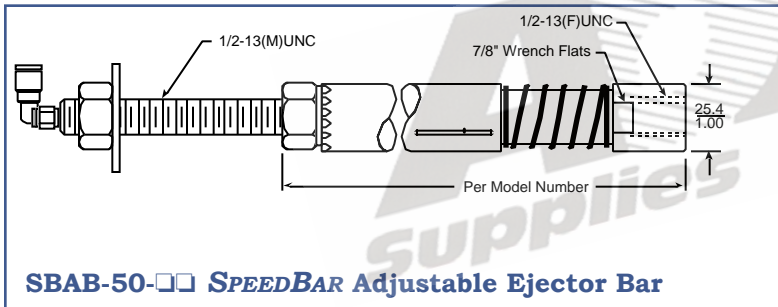
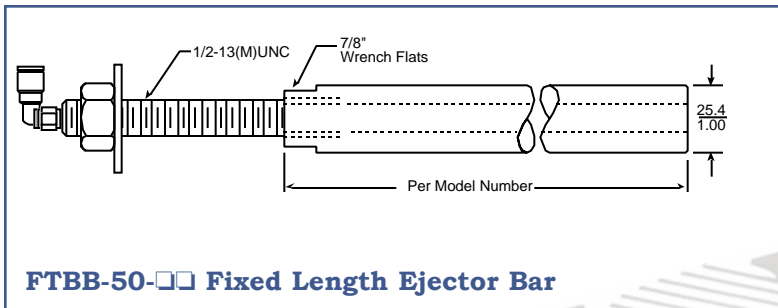
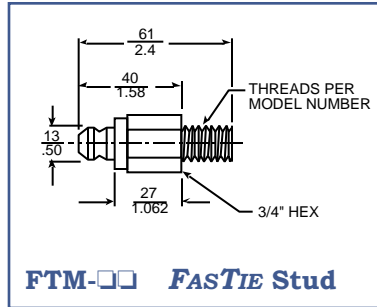
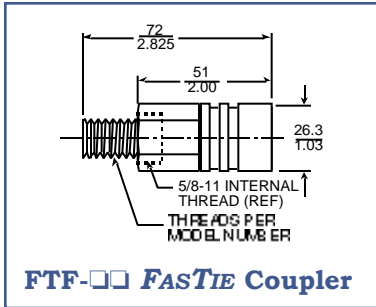

- Parts Included**
- manifold
 - (4) 1/8" elbow pneumatic fitting
 - (4) ø1/8" x 4ft tubing

Linear= $\frac{\text{mm}}{\text{inch}}$
(TYP)



FASTIE® Dimensions, 2-inch Components

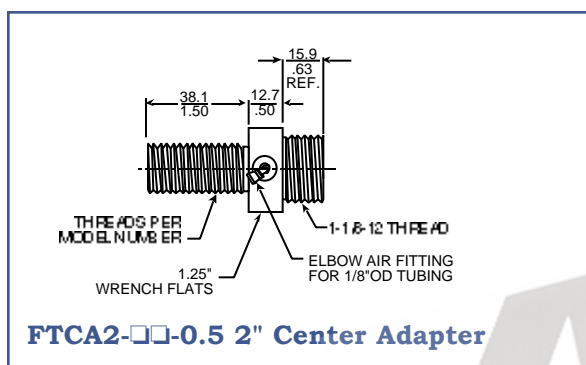
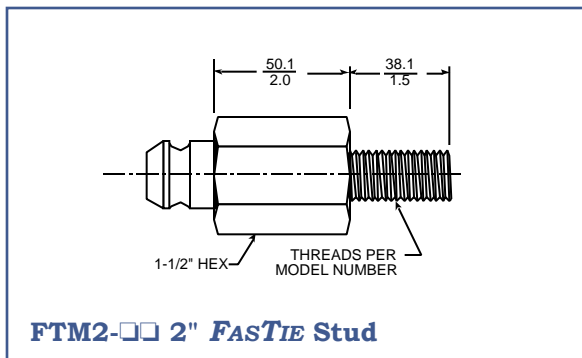
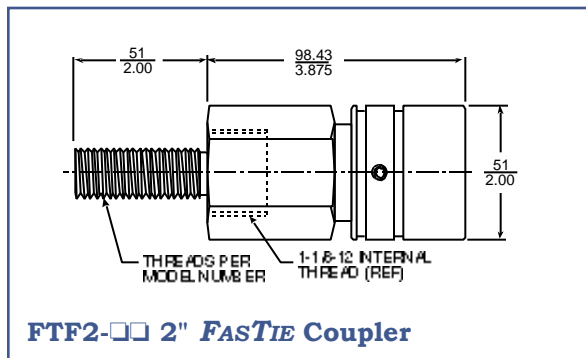

Linear = $\frac{\text{mm}}{\text{inch}}$
(TYP)

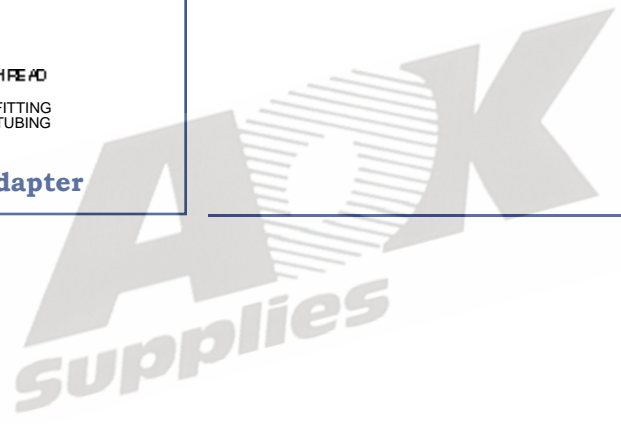

burger & brown engineering, inc.

www.smartflow-usa.com